

**Feeders: (For use with Incline Conveyors.)**

	Chain Driven Feeder	Integral Feeder
Lengths:	Lengths are 28", 43", 55", 79" and 90", depending upon conveyor width. (See chart below.)	Lengths are 28" and 32" depending upon conveyor width. (See chart below.)
Bed:	6" deep "box" construction x 12 ga. steel.	
Drive:	Powered by incline conveyor with roller chain and sprockets.	Powered by incline conveyor with continuous integral belt.
Tail Pulley:	4" dia. pulley with 1" extended shaft for 18" and 24" belt and 6" dia. pulley with 1-7/16" shaft for 30" and 36" belts.	
Bearings:	Self-aligning, sealed, flanged ball bearings.	
Snub Rollers:	2-1/8" dia. x 11 ga. roller mounted in bed section.	
Belt:	Chain driven feeder uses its own belt independent of the incline conveyor belt. Belt is 3 ply 28 oz. black friction surface.	Belt supplied with incline conveyor.
Belt Take-Up:	6" take-up bolts.	
Brackets / Pop-Out Rollers:	Installed at tail end to couple power feeder to other power or incline equipment. 1.9" dia. x 16 ga. pop-out rollers mounted in gravity brackets.	
Guards:	Pinch points are guarded for increased safety.	
Supports:	27" - 39" measuring from floor to top of belt.	

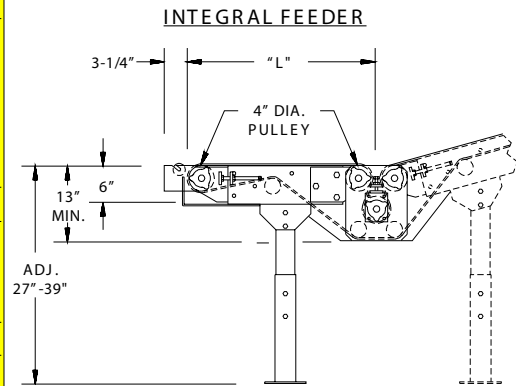
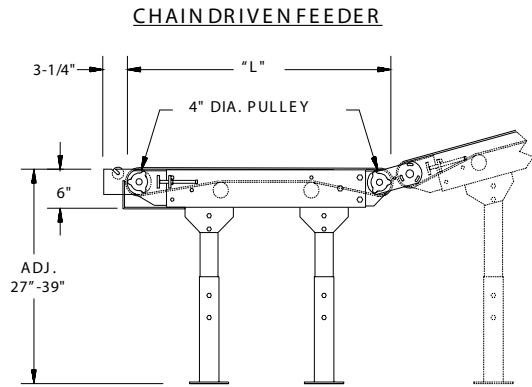

**Chain Driven Feeder Weights:**

Overall Widths	10"	18"	24"	28"	30"	34"	36"	42"
Lengths "L"	28"	28"	43"	55"	55"	75"	79"	90"
Weight (Lbs.)	100#	120#	138#	175#	184#	255#	264#	323#

**Integral Feeder Weights:**

Overall Widths	10"	18"	24"	28"	30"	34"	36"	42"
Lengths "L"	28"	28"	28"	28"	28"	28"	32"	32"
Weight (Lbs.)	120#	135#	156#	170#	180#	199#	294#	328#

**Medium Duty "M" Series Supports:**

Frame: 12 gauge. welded formed steel construction.  
 Pivot Plates: 35 degree adjustable standard.  
 Floor Anchors: Holes for 1/2" anchor bolts are provided in support feet.



"M" Series

Capacity  
1500# Ea.

Height to Top of Conveyor	
Model	Weights (Lbs.)
20, 21, 31	
13" - 16"	9#
16" - 19"	11#
19" - 22"	14#
22" - 28"	17#
26" - 32"	19#
* 29" - 41"	23#
40" - 52"	28#
52" - 64"	35#
64" - 76"	40#
76" - 88"	43#
86" - 98"	46#
98" - 110"	49#

\*Standard Support Height.

**Guard Rails:**

Vertical and Angle Solid Steel Guard Rails.

**Rod Type Ceiling Hangers:**

Widths - Widths correspond with width of conveyor ordered.  
 Lengths - 10' long fully threaded rod. To be used in place of standard stationary supports.

Extensions - Rod lengths may be extended using coupling nuts.

Rods - 5/8" diameter all thread rods.

Cross Pipe - 1-1/2" diameter pipe.

**Poly-Tier Supports:**

Capacity - 1500 lbs. per cross member and 3000 lbs. per support.

Widths - 16" to 42" standard overall widths.

Heights - Heights from 36" to 84" top of roller.

Tiers - Two tiers standard.

Knee Braces - 10 gauge formed angle steel. One set standard.

Installer must field drill for exact fit.

**Dust Pans: (Model 31)**

Solid steel to fit specified conveyor unit.