

Channel-End Stops:

Overall Widths	Lengths	Channel Stop Locations
42 1/2"	42 3/8"	-
48 1/2"	48 3/8"	21 3/16"
54 1/2"	54 3/8"	24 3/16"
60 1/2"	60 3/8"	27 3/16"

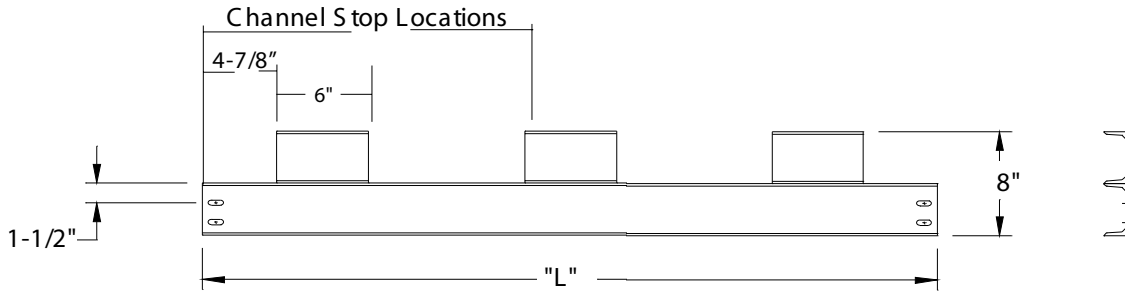

Heavy Duty "H" Series Supports:

Frame: 10 gauge, welded formed steel construction frame.
 Pivot Plates: 35 degree adjustable standard.
 Floor Anchors: Holes for 1/2" anchor bolts are provided in support feet.



"H" Series

Capacity
3000# Ea.

Height to Top of Conveyor	
Model	Weights (Lbs.)
58, 59, ITF, TTF	
10-1/4" - 12"	16#
12" - 15"	18#
* 15" - 18"	20#
18" - 21"	27#
21" - 24"	29#
24" - 30"	32#
30" - 36"	35#
36" - 48"	43#

*Standard Support Height.

Heavy Duty Blade Stops:

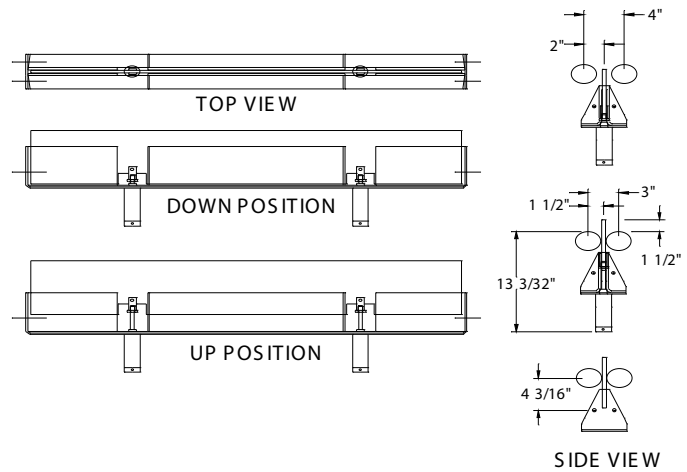

NOTES:

- Holes for 3/8 Hardware will need to be added to channels at assembly or field fit.
- Air pressure of 60 PSI required.
- Air cushion adjustment (Uniflo factory set). Turn screws all the way in and one turn out.

Guard Rails:

Angle Guard Rails - Leg In and Leg Out, Both.
1-1/2" x 1-1/2" x 12 gauge.

Fixed Channel Guard Rails - Straight channel and curved channel.
 Straight - 3-1/2" x 1-1/2" x 10 ga. both sides.
 Curved - 90 or 45 degree, inside, outside or both sides.