

## STANDARD SPECIFICATIONS:



Model TTF - 3 Strand Through-The-Frame Chain Transfer

Three-strand chain transfer mounted in a Model 48 (Roll-to-Roll Chain Driven Live Roller Pallet Conveyor)

### OPTIONAL EQUIPMENT:

Pneumatic Devices - Filter-regulator.  
 2 Strand Through-The-Frame Chain Transfer: 30" centers.  
 Paint: Special colors, powder coat.

### 3 Strand In-The-Frame Chain Transfers

Chain Centers:	Three strand chain centers are 15", with 5" roller centers.
Frame:	4" @ 5.4# and 6" @ 8.2# welded structural painted channel. (Model 48 not included.)
Drive:	Underside.
Transfer:	#60 roller chain.
Transfer Lift:	Linkage bars and vertically mounted air bags.
Transfer	1/2" above top of roller.
Clearance:	
Transfer Rate:	2 cycles per minute maximum.
Air Requirements:	60 PSI.
Motor:	1 HP 230/460 V., 3 phase, totally enclosed C-face.
Speed Reduction:	Right angle heavy duty worm gear speed reducer.
Paint:	Uniflo Dark Blue.
Electrical Controls:	115 V., double solenoid pneumatic valve. 115 V., limit switch to determine up/down position.
Supports:	14-3/4" minimum measuring from floor to top of roller.
Capacity:	1000 lbs./ft. live load, 4000 lbs. maximum unit load.

## STANDARD SPECIFICATION DRAWINGS:

NOTE: Model 48/49 Chain Driven Live Roller Conveyor must be specified separately when ordering.

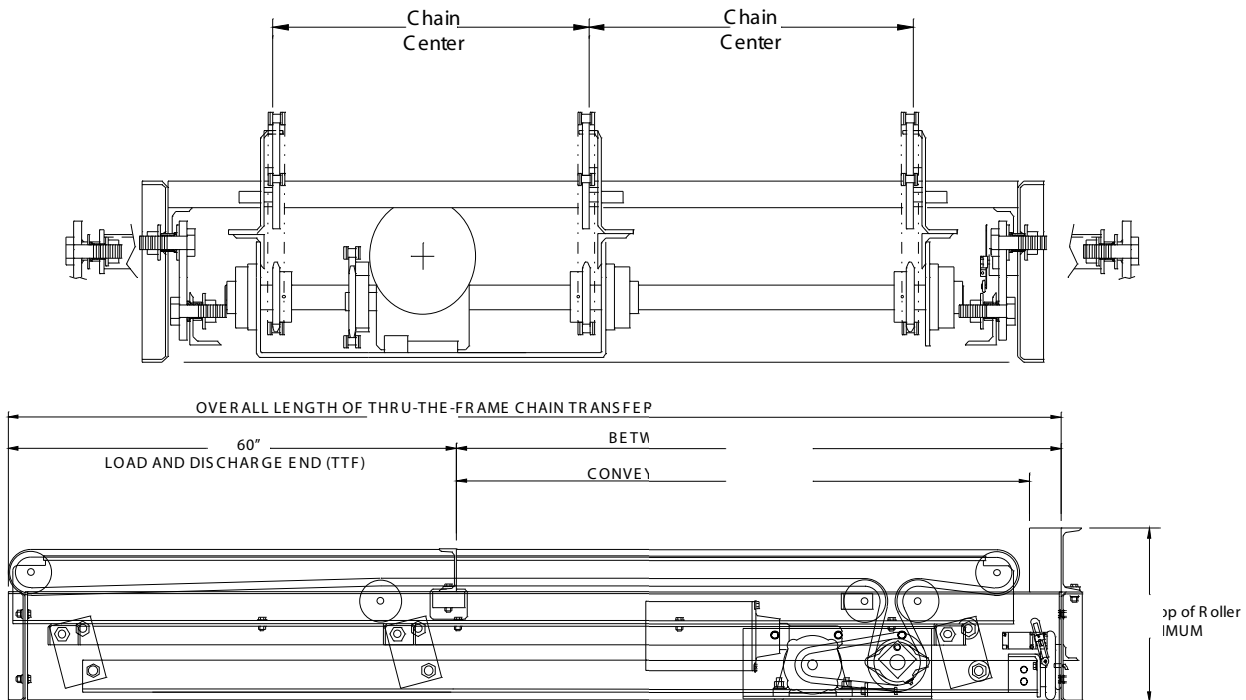

Overall Widths	Between Frame Widths	Conveying Surface Widths
48-1/2"	45"	42"
54-1/2"	51"	48"
60-1/2"	57"	54"

# Design a Pallet System For Flexibility and Productivity

Uniflo Technologies designs and manufactures heavy duty conveyors and equipment for the rugged requirements necessary to move pallets through any type of system or facility.

The system below was designed for the purpose of selectively dispatching pallets to three warehouse areas automatically, with as little fork truck involvement as possible.

An **Authorized Uniflo Technologies Distributor** can help plan and implement a system designed to take maximum advantage of available space, plus put your company ahead in the constant race for productivity gains.

## Accumulation Line

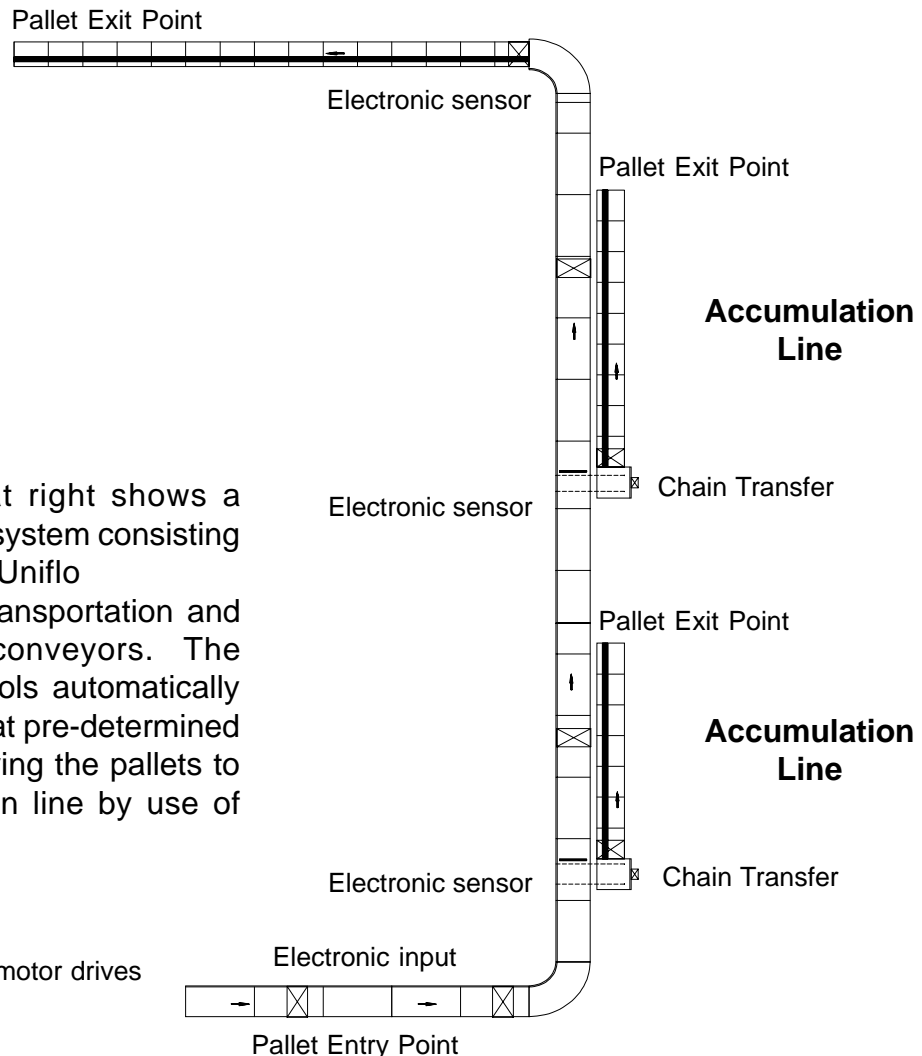

The drawing at right shows a pallet sortation system consisting of 362 feet of Uniflo Technologies transportation and accumulation conveyors. The electronic controls automatically sort the pallets at pre-determined exit points, moving the pallets to an accumulation line by use of chain transfers.

⊠ = Location of motor drives