

Model 35

STANDARD SPECIFICATIONS:



Model 35 - Belt Driven Live Roller Curve

Belt Driven Live Roller Curves

Overall Widths:	18", 24", 30", 36", and 42"
Between Frame Widths:	15", 21", 27", 33", and 39"
Radius:	32-1/2" radius for 24" and 30", 48" for 36" and 42" overall width.
Degrees:	90°, 45°, and 30°
Rollers:	2-1/2" x 1-11/16" x 14 ga. tapered galvanized steel.
Roller Channel:	6" x 1-1/2" x 12 gauge painted steel channel.
Drive:	Continuous v-belt, underside drive.
Take-up S heaves:	For adjusting the proper belt tension on the v-belt.
Pressure S heaves:	3-1/16" outside diameter x 3/8" Bore.
Motor:	1/2 H.P. 230/460 V., 3 phase, totally enclosed.
Speed Reduction:	Right angle worm gear reducer with v-belt from motor.
Roller Speed:	60 FPM.
Tangents:	Up to 10' maximum length for small radius (32.5"), and up to 5' maximum for large radius (48").
Slave Drive:	May be slave driven from Models 40, 41, 91, or by another Model 35.
Paint:	Uniflo Dark Blue.
Guards:	Pinch points are guarded for increased safety.
Supports:	29" - 41" measuring from floor to top of roller.
Capacity:	Live load per foot up to 40 lbs. for 1/2 HP motor based on 60 FPM. See capacity chart on page 6 of this brochure for more details.

OPTIONAL EQUIPMENT:

Motors: 3/4 or 1 horsepower

Guard Rails: Consult accessories section of this brochure for more details.

Supports: Consult accessories section of this brochure for more details.

Ceiling Hangers: Consult accessories section of this brochure for more details.

Paint: Special colors, powder coat.

Electrical Controls: Consult factory.

STANDARD SPECIFICATION DRAWINGS:

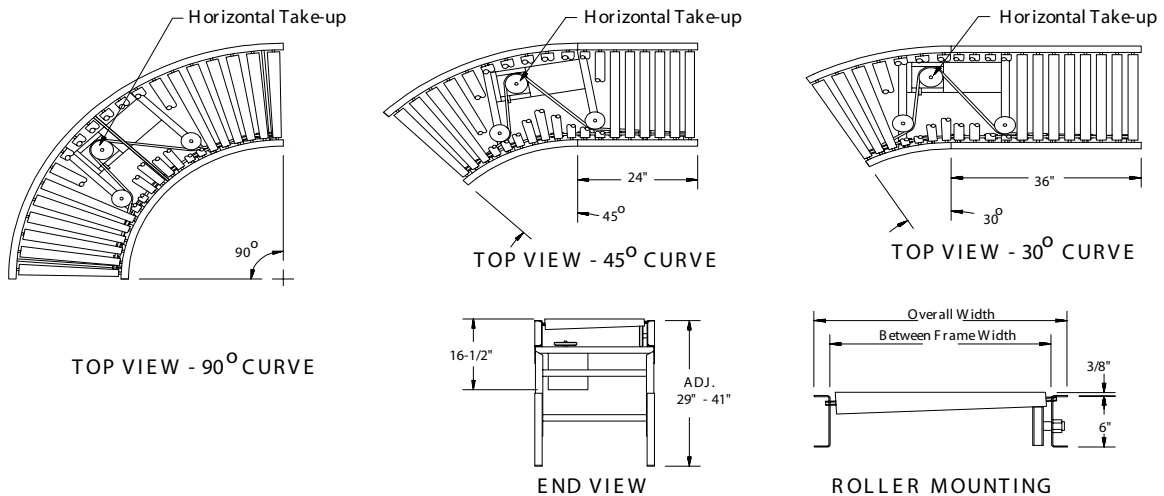

CONVEYOR WEIGHTS: (Weight in pounds.)

Overall Widths	18"	24"	30"	36"	42"
Between Frame Widths	15"	21"	27"	33"	39"
90°	375#	422#	469#	657#	726#
45°	362#	405#	448#	563#	615#
30°	360#	402#	444#	553#	603#
Tangent Wt./Ft.	23#	32#	41#	50#	59#

Capacity

HORSEPOWER CAPACITY (MODELS 26, 35, 40, 41, 91):

**Model 94 - use 50% of belt pull capacity for calculating horsepower.*

To calculate horsepower requirements for Slider Bed conveyors, follow these steps:

Step #1 - Calculate the live load per foot (weight of product per foot) of your application.

Step #2 - Determine Belt Pull Factor from Chart A below.

Step #3 - Use Belt Pull Factor with Chart B below to determine horsepower requirement for your application.

CHART A - Belt Pull Factor for Belt Driven Live Roller Conveyors

Live Load Per Foot	Overall Length														
	10	20	30	40	50	60	70	80	90	100	110	120	130	140	150
5	57	102	146	191	235	281	325	369	414	459	503	548	593	638	682
10	62	111	161	211	260	310	360	409	459	509	558	608	658	708	
15	67	121	176	231	285	340	395	449	504	559	613	668	723		
20	72	131	190	250	310	369	429	489	548	608	668	727			
25	77	141	206	271	335	400	465	529	594	659	723				
30	82	151	221	291	360	430	500	569	639	709					
40	92	171	251	331	410	490	570	649	729						
50	102	191	281	371	460	550	640	729							
60	112	211	311	411	510	610	710								
70	122	231	341	451	560	670									
80	132	251	371	491	610	729									
90	142	271	401	531	660										
100	152	291	431	571	710										

CHART B - Horsepower Requirement

Belt Pull Factor	Belt Speed (Feet Per Minute)									
	30	40	50	60	70	80	90	100	110	120
50	1/3									
100										
150	1/2									
200										
250	3/4									
300										
350	1									
400										
450										
500										

NOTE #1: Belt Driven Live Roller component and friction factor used in these calculations is 10%.

NOTE #2: Factor figures allow for 75% efficiency of gear reducer and 95% efficiency of chain drive. Maximum allowable belt pull for 4" dia. drive pulley is 350 lbs. and for 8" dia. drive pulley is 750 lbs. Chart B is a short means to determine horsepower requirements. For complete calculations see CEMA standards.

DIMENSION CHART (Models 40 and 41):

Overall Widths						Overall Widths									
Between Frame Widths						Between Frame Widths									
18" 24" 30" 36" 42"						18" 24" 30" 36" 42"									
15" 21" 27" 33" 39"						15" 21" 27" 33" 39"									
M O D E L 40	45°	"R"	32-1/2"	32-1/2"	32-1/2"	48"	48"	M O D E L 41	45°	"L"	63"	69"	75"	81"	87"
		"X"	29-1/4"	33-1/2"	37-3/4"	46-1/2"	50-3/4"			"X"	45-5/8"	49-13/16"	54-1/8"	58-5/16"	62-9/16"
		"Y"	42-1/16"	46-5/16"	50-9/16"	65-3/4"	70"			"Y"	45-5/8"	49-13/16"	54-1/8"	58-5/16"	62-9/16"
40	30°	"R"	32-1/2"	32-1/2"	32-1/2"	48"	48"	41	30°	"L"	72"	84"	96"	114"	114"
		"X"	48-15/16"	59-5/16"	69-11/16"	93-1/16"	93-1/16"			"X"	64-5/8"	75"	85-3/8"	100"	100"
		"Y"	56-3/16"	52-3/16"	58-3/16"	80-9/16"	80-9/16"			"Y"	37-5/16"	43-5/16"	49-5/16"	58-5/16"	58-5/16"