

Model 30

STANDARD SPECIFICATIONS:



Model 30 - Incline/
Decline Slider Bed

OPTIONAL EQUIPMENT:

Motors: 3/4 horsepower.

Underside Take-up: 18" of additional belt take-up.

Power Feeders: Chain driven or integral.

Guard Rails: Consult accessories section of this brochure for more details.

Supports: Consult accessories section of this brochure for more details.

Ceiling Hangers: Consult accessories section of this brochure for more details.

Paint: Special colors, powder coat.

Electrical Controls: Consult factory.

Incline/Decline Slider Bed Belt Conveyors

Bed Lengths:	5'-0" or 10'-0" increments.
Overall Widths:	24", 30", 36", 42"
Belt Widths:	18", 24", 30", 36"
Bed:	6" deep, 12 gauge formed painted steel box type.
Undertrussing:	Provided as standard on conveyors 25' to 45' in length. Joint support angles at bed joints are provided as standard on machines under 25' long.
Drive / Pulley:	8" dia. underside center drive pulley with 1-7/16" dia. shaft, crowned and fully lagged.
Pop-out Roller:	1.9" dia. x 16 ga. pop-out roller mounted at drive pulley.
Tail Pulley:	4" dia. pulley with 1" dia. shaft for 18" and 24" wide belt, 6" dia. pulley with 1-7/16" dia. shaft for 30" and 36" belt.
Bearings:	Self-aligning, sealed flange ball bearings.
Snub Rollers:	2-1/2" dia. x 11 ga. with 9/16" hex shaft at drive pulley. 2-1/8" dia. x 11 ga. with 7/16" hex shaft at tail pulley. Bearings are sealed and grease-packed.
Return Idler:	One 1.9" dia. x 16 ga. galvanized roller per bed section with 7/16" hex shaft.
Belt:	2 ply 150 black roughtop.
Belt Take-Up:	6" take-up bolts.
Motor:	1 HP, 230/460 V., 3 phase, totally enclosed C-faced.
Belt Speed:	60 FPM.
Speed Reduction:	Right angle worm gear speed reducer connected to the drive pulley by #50 roller chain and sprockets.
Nose-Over:	Single or double.
Paint:	Uniflo Dark Blue.
Guards:	Pinch points are guarded for increased safety.
Supports:	29" - 41" measuring from floor to top of belt.
Capacity:	750 lbs. belt pull. See capacity chart on page 6 of this brochure for more details.

STANDARD SPECIFICATION DRAWINGS:

8" Center Drive Single Nose-Over - (Guarding removed for clarity.)

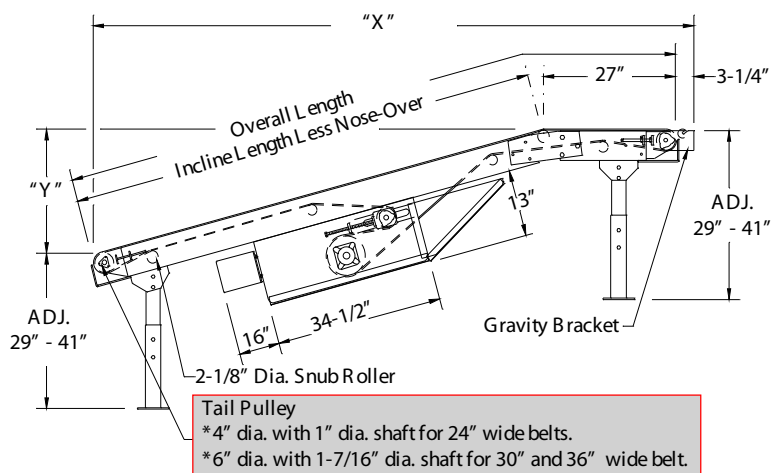

8" Center Drive Double Nose-Over - (Guarding removed for clarity.)

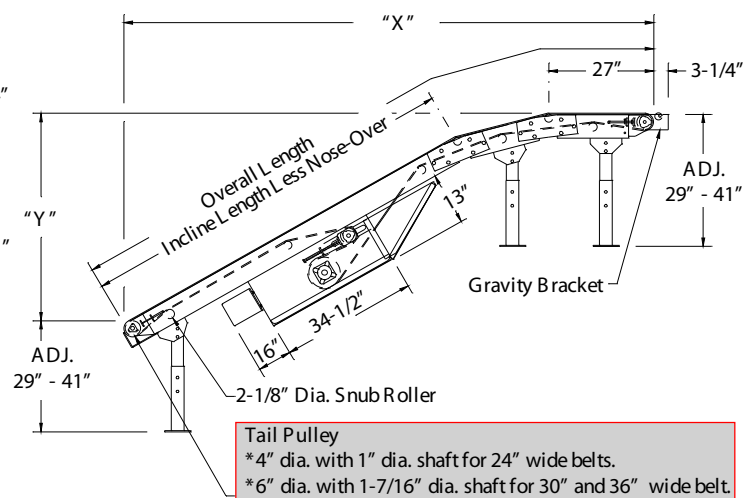

CONVEYOR WEIGHTS:

Overall Widths	24"	30"	36"	42"
Belt Widths	18"	24"	30"	36"
5' Conveyor Weight (Lbs.)	586#	591#	620#	684#
Weight Per Foot (Lbs.)	31#	40#	45#	50#

HORSEPOWER CAPACITY (MODELS 11, 16):

To calculate horsepower requirements for Slider Bed conveyors, follow these steps:

Step #1 - Calculate the live load per foot (weight of product per foot) of your application.

Step #2 - Determine Belt Pull Factor from Chart A below.

Step #3 - Use Belt Pull Factor with Chart B below to determine horsepower requirement for your application.

CHART A - Belt Pull Factor for Slider Bed Conveyors

Live Load Per Foot	Overall Length														
	10	15	20	25	30	35	40	45	50	55	60	70	80	90	100
5	28	43	57	82	85	100	114	128	142	156	171	199	228	256	284
10	52	77	103	129	154	180	206	231	257	283	309	360	412	463	514
15	77	112	149	186	223	261	298	335	372	409	447	521	596	670	744
20	97	146	195	244	278	325	390	438	487	536	585	682	780		
25	120	181	241	301	361	422	482	542	602	662	723				
30	143	215	287	359	430	502	573	645	717						
40	189	284	379	474	568	663	757								
50	235	353	471	589	706										

CHART B - Horsepower Requirement

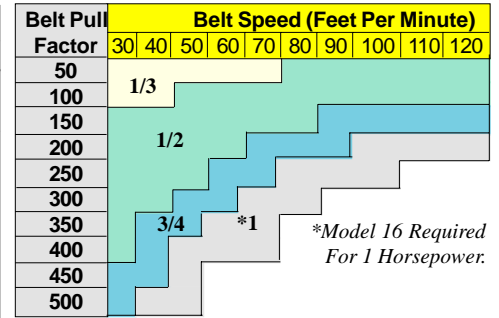

NOTE #1: Slider bed component and friction factor used in these calculations is 46%.

NOTE #2: Factor figures allow for 75% efficiency of gear reducer and 95% efficiency of chain drive. Maximum allowable belt pull for 4" dia. drive pulley is 350 lbs. and for 8" dia. drive pulley is 750 lbs. Chart B is a short means to determine horsepower requirements. For complete calculations see CEMA standards.

HORSEPOWER CAPACITY (MODEL 30):

Step #1: Determine the Overall Length of conveyor from Incline/Decline Calculation Chart.

Step #2: On the Live Load Capacity Chart, choose the Overall Length nearest your requirements.

Step #3: Select the incline or decline angle appropriate to determine the correct horsepower needed to convey the load.

Incline/Decline Calculation Charts 8" Center Drive									
Double Nose-Over					Single Nose-Over				
Up to 24" Belt Width (4" Dia. Tail Pulley with 1" Dia. Shaft)					Tail Pulley with 1" Dia. Shaft				
Overall Lengths	∠ = 15°		∠ = 25°		Overall Lengths	∠ = 15°		∠ = 25°	
	X	Y	X	Y		X	Y	X	Y
10'	9'-8"	2'-1"	9'-4"	2'-11"	8'	7'-9"	1'-6"	7'-5"	2'-10"
15'	14-6	3-4	13-10	5-0	13'	12-7	2-10	11-11	4-11
20'	19-4	4-8	18-5	7-2	18'	17-5	4-2	16-5	7-0
25'	24-1	5-11	22-11	9-3	23'	23-3	5-3	21-1	9-2
30'	29-0	7-3	27-6	11-4	28'	27-1	6-9	25-6	11-3
35'	33-9	8-6	32-0	13-6	33'	31-10	8-0	30-0	13-4
40'	38-8	9-10	36-6	15-7	38'	36-9	9-4	34-7	15-6
45'	43-5	11-2	41-1	17-9	43'	44-6	10-7	39-1	17-7

Incline/Decline Calculation Charts 30" Belt Width (6" Dia. Tail Pulley with 1-7/16" Dia. Shaft)									
Double Nose-Over					Single Nose-Over				
Overall Lengths	∠ = 15°		∠ = 25°		Overall Lengths	∠ = 15°		∠ = 25°	
	X	Y	X	Y		X	Y	X	Y
10'-4"	10'-0"	2'-1"	9'-8"	2'-11"	8'-4"	8'-1"	1'-6"	7'-9"	2'-10"
15'-4"	14-10	3-4	14-2	5-0	13'-4"	12-11	2-10	12-3	4-11
20'-4"	19-8	4-8	18-9	7-2	18'-4"	17-9	4-2	16-9	7-0
25'-4"	24-5	5-11	23-3	9-3	23'-4"	22-7	5-6	21-4	9-4
30'-4"	29-4	7-3	27-10	11-4	28'-4"	27-5	6-9	25-10	11-3
35'-4"	34-1	8-6	32-4	13-6	33'-4"	32-2	8-0	32-4	13-4
40'-4"	39	9-10	36-10	15-7	38'-4"	37-1	9-4	34-11	15-6
45'-4"	43-9	11-2	41-5	17-9	43'-4"	41-10	10-7	39-5	17-7

LIVE LOAD CAPACITY IN POUNDS/FT. (WITH FEEDER)					
Calculations based on 60 FPM					
Conveyor Dimensions			∠ = 15°		∠ = 25°
Overall Widths	Belt Widths	Overall Lengths	Horsepower		Horsepower
			3/4	1	3/4 1
24"	18"	10'0"	27	40	24 35
		20'0"	14	20	11 17
		30'0"	9	13	7 11
30"	24"	10'0"	26	39	23 35
		20'0"	13	20	11 17
		30'0"	8	13	7 11
36"	30"	10'4"	25	38	22 34
		20'4"	12	19	10 16
		30'4"	7	12	6 10

LIVE LOAD CAPACITY IN POUNDS/FT. (WITH FEEDER)					
Calculations based on 60 FPM					
Conveyor Dimensions			∠ = 15°		∠ = 25°
Overall Widths	Belt Widths	Overall Lengths	Horsepower		Horsepower
			3/4	1	3/4 1
24"	18"	10'0"	35	52	31 45
		20'0"	16	24	13 19
		30'0"	10	15	8 12
30"	24"	10'0"	35	52	30 45
		20'0"	15	23	13 19
		30'0"	9	14	8 12
36"	30"	10'4"	34	51	29 44
		20'4"	14	22	12 18
		30'4"	8	13	7 11