

STANDARD SPECIFICATIONS:



Model 20 - Horizontal "System"
Roller Bed Belt Conveyor

HORIZONTAL STRAIGHT ROLLER BED BELT CONVEYORS

Bed Lengths:	5'-0" or 10--0" increments.
Overall Widths:	24", 30", 36", 42"
Between Frame Widths:	21", 27", 33", 39"
Belt Widths:	18", 24", 30", 36"
Rollers:	1.9" dia. x 16 gauge galvanized with 7/16" spring loaded hex shafts.
Roller Centers:	3", 6", 9"
Bed Frame:	6" deep x 10 gauge steel "J" channel bed with cross bracing.
Drive / Pulley:	8" dia. end drive crowned and fully lagged with 1-7/16" dia. shaft.
Tail Pulley:	4" dia. with 1" dia. shaft for 18" and 24" wide belts; 6" dia. with 1-7/16" dia. shaft for 30" and 36" wide belts. Both pulleys are crowned.
Pulley Bearings:	Self-aligning, sealed, flanged ball bearings.
Snub Idler:	2-1/2" dia. x 11 ga. with 9/16" hex shaft at drive end, 2-1/8" dia. x 11 ga. with 7/16" hex shaft at tail end. Bearings are sealed and grease-packed.
Return Idler:	1.9" dia. x 16 ga. adjustable with sealed grease-packed ball bearings and 7/16" hex shaft.
Belt:	PVC-120 Black friction surface both sides.
Belt Take-Up:	6" take-up bolts at tail pulleys to insure proper belt tension.
Motor:	1/2 H.P. 230/460 V., 3 phase, totally enclosed C-faced.
Belt Speed:	60 FPM.
Speed Reduction:	Right angle worm gear reducer connected to drive pulley by #50 roller chain and sprockets.
Paint:	Uniflo Dark Blue.
Guards:	Pinch points are guarded for increased safety.
Supports:	29" - 41" measuring from floor to top of belt.
Capacity:	750 lbs. belt pull. See capacity chart on page 2 of this brochure for more details.

OPTIONAL EQUIPMENT:

- Motors:** 3/4 and 1 horsepower.
- Drives:** Underside mounted center drive.
- Underside Take-up:** 18" of additional belt take-up. See drawing below.
- Power Feeders:** Chain driven.
- Belt Speeds:** From 25 FPM to 135 FPM.
- Guard Rails:** Consult accessories section of this brochure for more details.
- Supports:** Consult accessories section of this brochure for more details.
- Ceiling Hangers:** Consult accessories section of this brochure for more details.
- Paint:** Special colors, powder coat.
- Electrical Controls:** Consult factory.

STANDARD SPECIFICATION DRAWINGS:

(Guarding removed for clarity.)

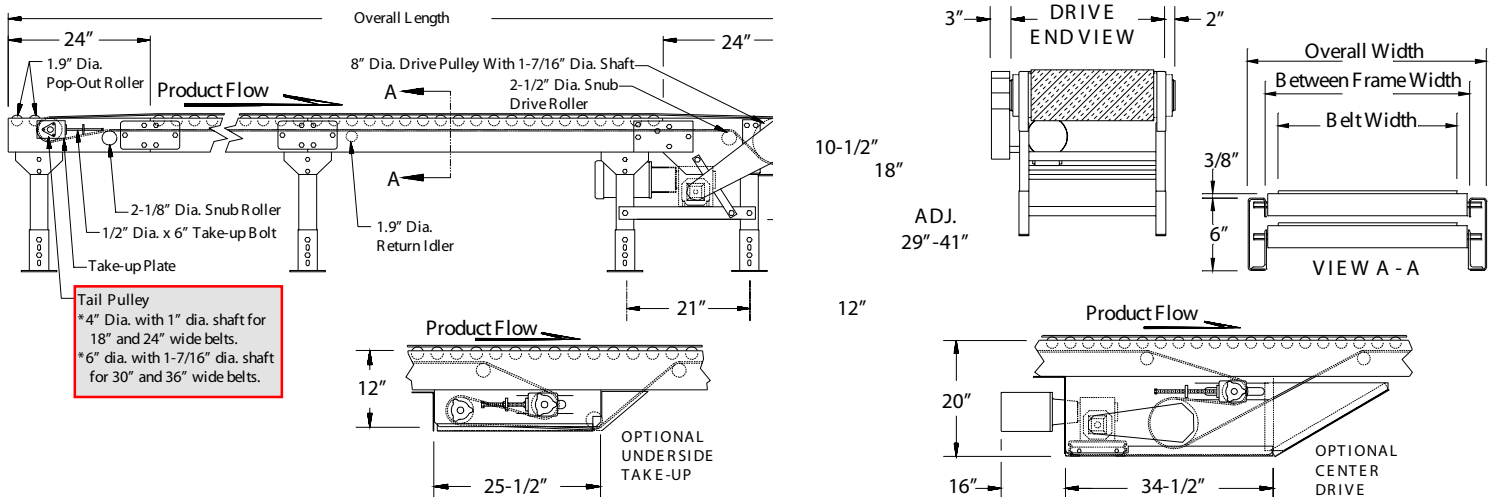

CONVEYOR WEIGHTS:

Overall Widths		24"	30"	36"	42"
Between Frame Widths		21"	27"	33"	39"
Belt Widths		18"	24"	30"	36"
3" Centers	10' Conveyor Weight (Lbs.)	571#	640#	708#	778#
	Weight Per Foot (Lbs.)	32#	38#	43#	48#
6" Centers	10' Conveyor Weight (Lbs.)	499#	550#	600#	649#
	Weight Per Foot (Lbs.)	27#	32#	38#	39#
9" Centers	10' Conveyor Weight (Lbs.)	469#	512#	555#	597#
	Weight Per Foot (Lbs.)	21#	24#	26#	29#

HORSEPOWER CAPACITY (Models 20, 21):

To calculate horsepower requirements for Roller Bed conveyors, follow these steps:

Step #1 - Calculate the live load per foot (weight of product per foot) of your application.

Step #2 - Determine Belt Pull Factor from Chart A below.

Step #3 - Use Belt Pull Factor with Chart B below to determine horsepower requirement for your application.

CHART A - Belt Pull Factor for Roller Bed Conveyors (Rollers on 6" centers)

Live Load Per Foot	Overall Length														
	10	15	20	25	30	40	50	60	70	80	90	100	120	140	150
5	13	20	26	33	39	52	65	78	91	104	117	130	156	183	196
10	16	24	32	40	48	64	80	96	111	127	143	146	191	222	238
15	19	28	38	47	56	75	94	113	132	150	169	188	226	263	282
20	22	33	43	54	65	87	108	126	152	173	195	216	260	303	325
25	25	37	49	61	74	98	123	147	172	196	221	245	295	344	368
30	27	41	55	69	82	110	137	165	192	219	247	274	329	384	411
40	33	50	66	84	99	132	165	198	231	264	298	330	397	463	496
50	39	58	78	97	117	156	195	234	272	311	350	389	467	545	584

CHART B - Horsepower Requirement

Belt Pull Factor	Belt Speed (Feet Per Minute)										
	30	40	50	60	70	80	90	100	110	120	
50	1/3										
100											
150	1/2										
200											
250	3/4										
300											
350	1										
400											
450											
500											

NOTE #1: Roller bed component and friction factor used in these calculations is 5%.

NOTE #2: Factor figures allow for 75% efficiency of gear reducer and 95% efficiency of chain drive. Maximum allowable belt pull for 4" dia. drive pulley is 350 lbs. and for 8" dia. drive pulley is 750 lbs. Chart B is a short means to determine horsepower requirements. For complete calculations see CEMA standards.