

Model 1

Model 2

STANDARD SPECIFICATIONS:

STEEL AND ALUMINUM SKATEWHEEL CONVEYORS:



	Model 1	Model 2
Lengths:	5'-0" or 10--0" increments.	
Widths:	12", 18", and 24"	
Wheels:	Zinc plated steel wheels are 1-15/16" dia. x 5/16" face with a steel hardened race way and a 13/16" wide cone.	Aluminum wheels are 1-15/16" dia. x 5/16" face with a steel hardened race way and a 13/16" wide cone.
	Each zinc plated and aluminum wheel contains seven 1/4" hardened and ground steel balls. The lightly oiled, baffled construction is designed to keep out dirt.	
Wheels Per Foot:	10, 16, and 20	
Frame:	1" x 2-1/2" x 1" x 12 ga. formed steel channel.	1" x 2-1/2" x 1" x 1/8" heat treated aluminum extrusion.
Axles:	Lengths: 10-5/8", 16-5/8", 22-5/8", 1/4" dia. cold drawn steel, set on 3" centers and secured with a 1/4" -20 lock nut.	
	The 12" and 18" sections have two 12 ga. x 1" axle supports while the 24" sections have three axle supports.	The 12" and 18" sections have two 1/8" x 1" aluminum x 1" axle supports while the 24" sections have three axle supports.
Curves:	90 deg.	
Spurs:	45 deg. and 90 deg.	
Couplings:	Each 5' and 10' section is equipped with a hook and rod connector as standard. The slotted hook permits minor lateral movement.	
Spacers:	PVC Black.	
Capacity:	55 lbs. per wheel.	45 lbs. per wheel.

WHEEL PATTERNS AVAILABLE:

CONVEYOR WEIGHTS:

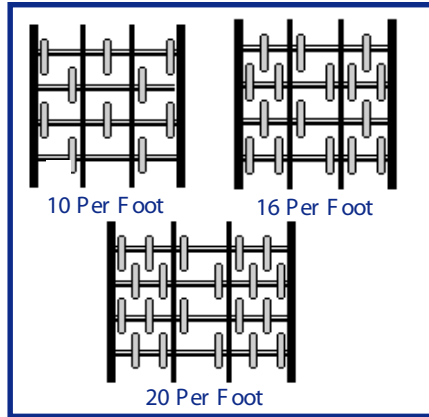

10' Straight Sections

12" Overall Width		18" Overall Width		24" Overall Width				
Wheels Per Ft.	Weight (Lbs.)	Wheels Per Ft.	Weight (Lbs.)	Wheels Per Ft.	Weight (Lbs.)			
	Steel	Alum.	Steel	Alum.	Steel	Alum.		
10	65#	35#	16	83#	51#	20	98#	60#

45° and 90° Curves

Deg.	12" Overall Width		18" Overall Width		24" Overall Width				
	Wheels Per Ft.	Weight (Lbs.)	Wheels Per Ft.	Weight (Lbs.)	Wheels Per Ft.	Weight (Lbs.)			
		Steel	Alum.	Steel	Alum.	Steel	Alum.		
90	10	40#	23#	16	52#	30#	20	72#	43#
45	10	18#	10#	16	26#	15#	20	38#	22#

OPTIONAL EQUIPMENT:

Angle End Stop: Consult accessories section of this brochure for more details.

Guard Rails: 3/4" fixed steel tubular pipe with mounting apparatus, 3-3/4" from center horizontal rail to top of wheel.

Tripod Support: Consult accessories section of this brochure for more details.

Medium Duty "M" Series Supports: Consult accessories section of this brochure for more details.